

# Body-Solid

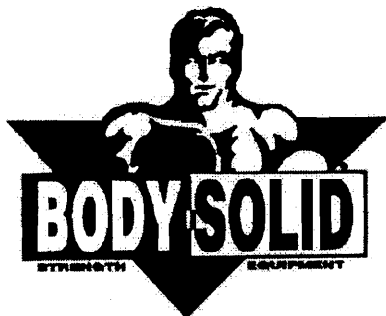

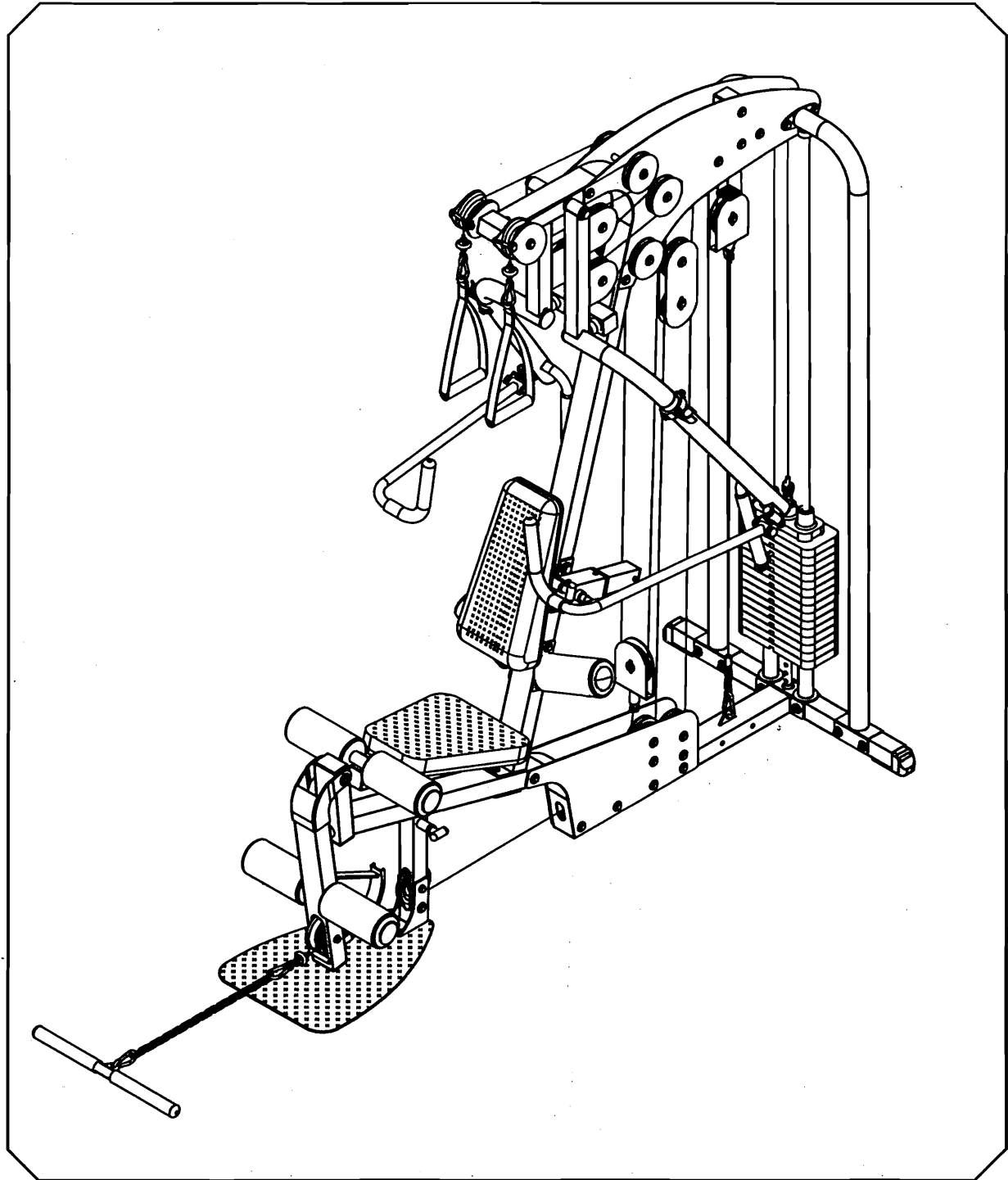











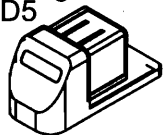



BODY-SOLID, Inc.  
1900 S. Des Plaines Ave.  
Forest Park, IL 60130 USA  
Phone: (708) 427-3555  
Fax: (708) 427-3556  
[www.bodysolid.com](http://www.bodysolid.com)

**EXM1950.3 OWNER'S MANUAL**

# EXM1950 ASSEMBLY INSTRUCTIONS





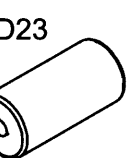
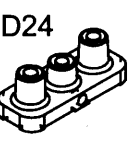
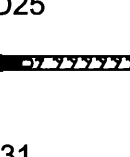
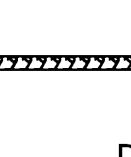









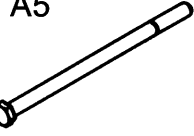











## HARDWARE ILLUSTRATION

Qty.

	D2. 2"X2"X1.8t END CAP (9211-005) ----- [3PCS]
	D3. 2"X2"X2.5t END CAP (9211-006) ----- [2PCS]
<td>D5. 50X50X2.5t FOOT CAP (9211-025) ----- [2PCS]</td>	D5. 50X50X2.5t FOOT CAP (9211-025) ----- [2PCS]
	D6. ø5/8"X26L STEEL BUSHING (8110-037) ----- [10PCS]
	D7. ø5/8"X35L STEEL BUSHING (8110-043) ----- [2PCS]
	D8. ø5/8"X75L STEEL BUSHING (8110-044) ----- [4PCS]
	D9. ø5/8"X8L STEEL BUSHING (8110-045) ----- [6PCS]
<td>D12. ø10X29L PULLEY SPACER (8530-011) ----- [2PCS]</td>	D12. ø10X29L PULLEY SPACER (8530-011) ----- [2PCS]
	D13. ø3/4" SHAFT COLLAR (9211-046) ----- [2PCS]
	D15. ø3" NYLON WASHER (9214-008) ----- [2PCS]
	D16. ø2 1/2" RUBBER DONUT (9310-010) ----- [2PCS]
<td>D18. ø8 SPRING SNAP LINK (8810-001) ----- [5PCS]</td>	D18. ø8 SPRING SNAP LINK (8810-001) ----- [5PCS]
	D19. ø4 1/4"X22t PULLEY (9213-002) ----- [19PCS]
	D20. ø3" PULLEY (9213-006) ----- [1PCS]
<td>D22. ø110X22t PULLEY (9213-022) ----- [1PCS]</td>	D22. ø110X22t PULLEY (9213-022) ----- [1PCS]
	D23. ø4"X23X8" FOAM ROLLER (9161-009) ----- [6PCS]
<td>D25. SELECTOR BAR (8210-042A) ----- [1PCS]</td>	D25. SELECTOR BAR (8210-042A) ----- [1PCS]
<td>D27. 60X50 NYLON BUSHING (9211-033) ----- [2PCS]</td>	D27. 60X50 NYLON BUSHING (9211-033) ----- [2PCS]
	D28. ø2" ROUND END CAP (9211-020) ----- [4PCS]
<td>D30. 38X38mm RUBBER PAD (9310-001) ----- [1PCS]</td>	D30. 38X38mm RUBBER PAD (9310-001) ----- [1PCS]
<td>D32. 4455mm STEEL CABLE ----- [1PCS]</td>	D32. 4455mm STEEL CABLE ----- [1PCS]
<td>D34. 2670mm STEEL CABLE ----- [1PCS]</td>	D34. 2670mm STEEL CABLE ----- [1PCS]
<td>D36. ANKLE STRAP(50NAS3) ----- [1PCS]</td>	D36. ANKLE STRAP(50NAS3) ----- [1PCS]
	D37. ø5/8" ROUND END CAP(9211-015) ----- [2PCS]
	D38. ø1" ROUND END CAP(9260-021) ----- [6PCS]
	D39. ø1" ROUND END CAP(9211-022) ----- [4PCS]
	D40. ø1" ROUND END CAP(9211-085) ----- [2PCS]
<td>D26. 4455mm STEEL CABLE ----- [1PCS]</td>	D26. 4455mm STEEL CABLE ----- [1PCS]
<td>D28. 2670mm STEEL CABLE ----- [1PCS]</td>	D28. 2670mm STEEL CABLE ----- [1PCS]
<td>D30. ANKLE STRAP(50NAS3) ----- [1PCS]</td>	D30. ANKLE STRAP(50NAS3) ----- [1PCS]
	D31. ø5/8" ROUND END CAP(9211-015) ----- [2PCS]
	D32. ø1" ROUND END CAP(9260-021) ----- [6PCS]
	D33. ø1" ROUND END CAP(9211-022) ----- [4PCS]
	D34. ø1" ROUND END CAP(9211-085) ----- [2PCS]
<td>D36. 4455mm STEEL CABLE ----- [1PCS]</td>	D36. 4455mm STEEL CABLE ----- [1PCS]
<td>D38. 2670mm STEEL CABLE ----- [1PCS]</td>	D38. 2670mm STEEL CABLE ----- [1PCS]
<td>D40. ANKLE STRAP(50NAS3) ----- [1PCS]</td>	D40. ANKLE STRAP(50NAS3) ----- [1PCS]

# EXM1950 ASSEMBLY INSTRUCTIONS

## HARDWARE ILLUSTRATION

		Qty.
A1		A1. 1/2"X4" HEX HEAD BOLT ----- [2PCS]
A2		A2. 1/2"X3 1/4" HEX HEAD BOLT ----- [1PCS]
A3		A3. 1/2"X3" HEX HEAD BOLT ----- [1PCS]
A4		A4. 1/2"X2 3/4" HEX HEAD BOLT ----- [4PCS]
A5		A5. 3/8"X6 1/2" HEX HEAD BOLT ----- [3PCS]
A6		A6. 3/8"X4 1/4" HEX HEAD BOLT ----- [4PCS]
A7		A7. 3/8"X4" HEX HEAD BOLT ----- [9PCS]
A8		A8. 3/8"X3 3/4" HEX HEAD BOLT ----- [8PCS]
A9		A9. 3/8"X3 1/4" HEX HEAD BOLT ----- [2PCS]
A10		A10. 3/8"X3" HEX HEAD BOLT ----- [4PCS]
A11		A11. 3/8"X2 3/4" HEX HEAD BOLT ----- [8PCS]
A12		A12. 3/8"X1 3/4" HEX HEAD BOLT ----- [8PCS]
A13		A13. 3/8"X2" ROUND BOLT ----- [1PCS]
A14		A14. 5/16"X2 3/4" HEX HEAD BOLT ----- [2PCS]
A15		A15. 5/16"X1 3/4" HEX HEAD BOLT ----- [2PCS]
A16		A16. 10LB PIN ----- [1PCS]
A17		A17. STEEL CHAIN ----- [1PCS]
A18		A18. □12 BUSHING (8890-010) ----- [1PCS]
B1		B1. 1/2" LOCK NUT ----- [1PCS]
B2		B2. 1/2" NYLON LOCK NUT ----- [7PCS]
B3		B3. 3/8" NYLON LOCK NUT ----- [44PCS]
C1		C1. 1/2" (I.D)WASHER ----- [7PCS]
C2		C2. 3/8" (I.D)WASHER ----- [82PCS]
C4		C4. 5/16" (I.D) WASHER ----- [4PCS]
C5		C5. 1/2" SPRING WASHER ----- [1PCS]
C6		C6. 5/16" SPRING WASHER ----- [4PCS]
C8		C8. M10 RADIAN WASHER ----- [4PCS]

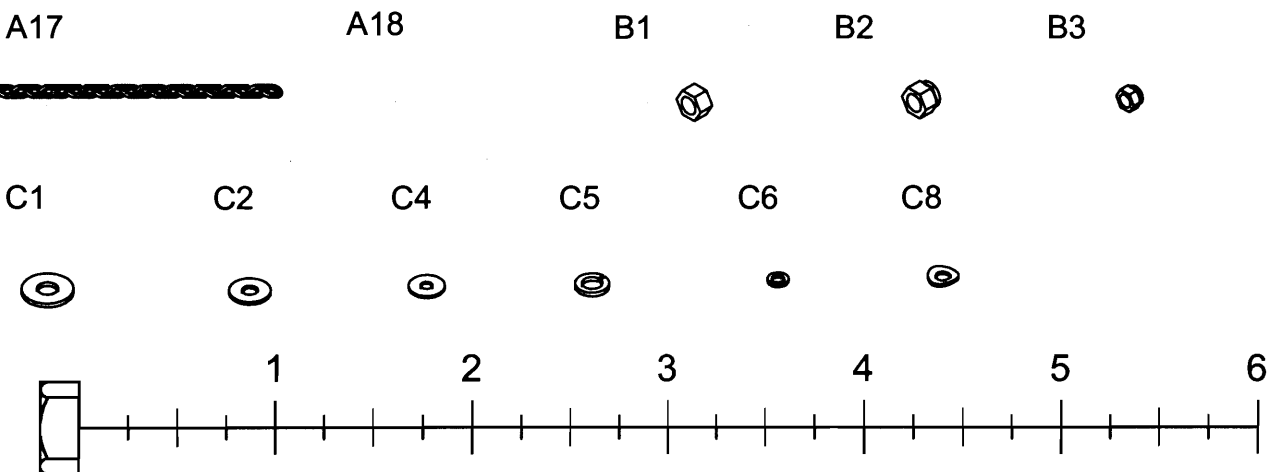

# EXM1950 ASSEMBLY INSTRUCTIONS

## PARTS ILLUSTRATION

A-1 [1PCS]

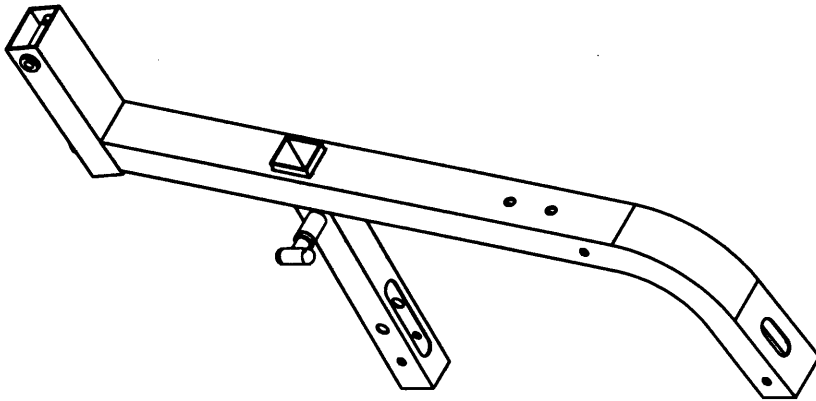

B-1 [1PCS]

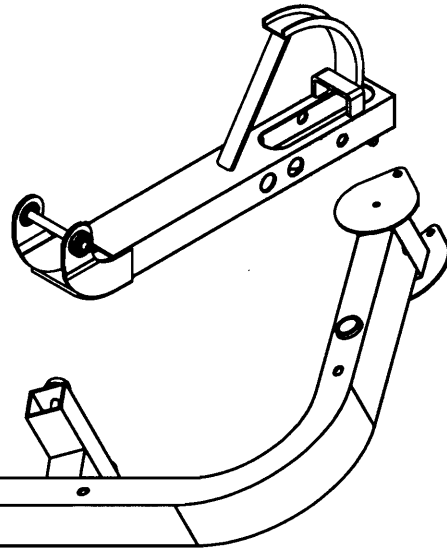

C [1PCS]

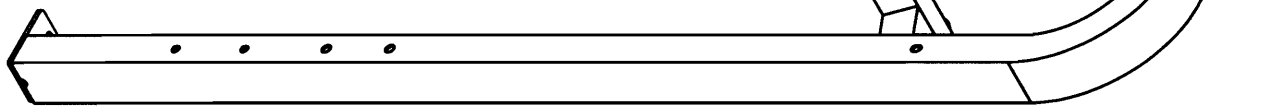

D [1PCS]

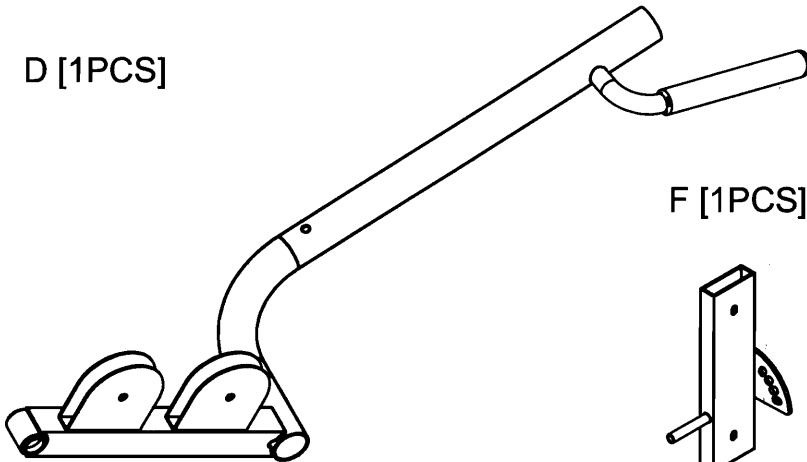

F [1PCS]

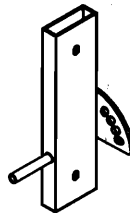

G [1PCS]

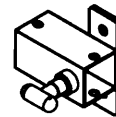

H [1PCS]

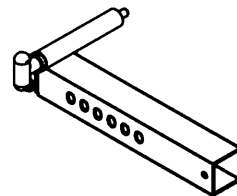

E [1PCS]

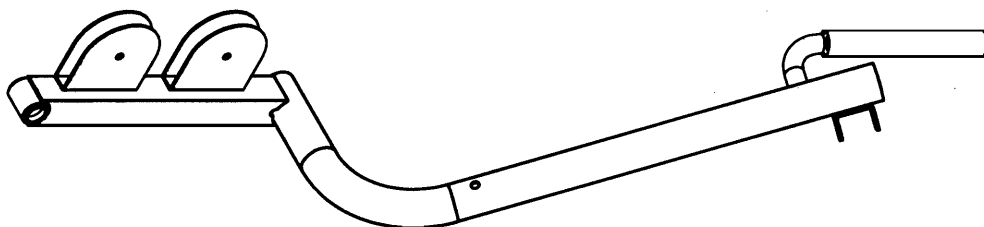

I [1PCS]

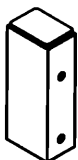

J [1PCS]

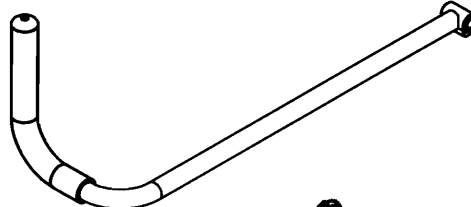

K [1PCS]

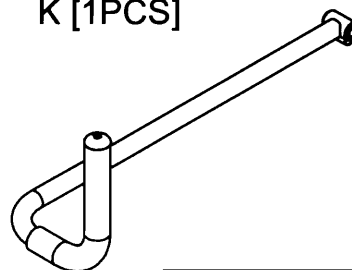

# EXM1950 ASSEMBLY INSTRUCTIONS

## PARTS ILLUSTRATION

L [2PCS]



M [2PCS]

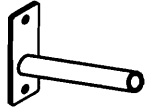

N [1PCS]

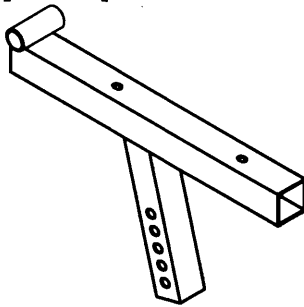

P [1PCS]

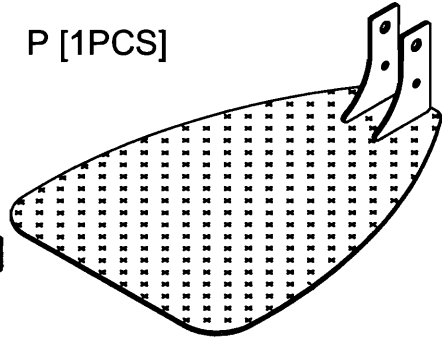

O [2PCS]



Q [1PCS]



R [1PCS]



S [2PCS]



T [1PCS]



U [2PCS]

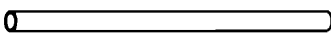

V [1PCS]



W [1PCS]

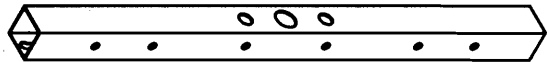

X [2PCS]

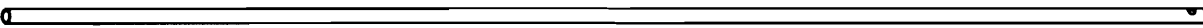

Y [2PCS]

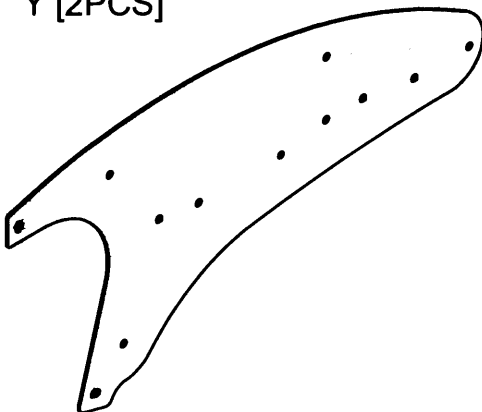

Z [2PCS]

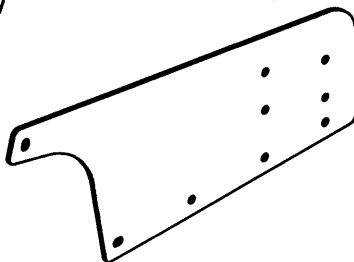

AA [2PCS]



## PARTS ILLUSTRATION

AB [1PCS]

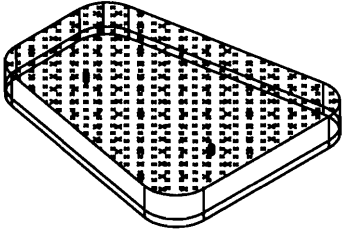

AC [1PCS]

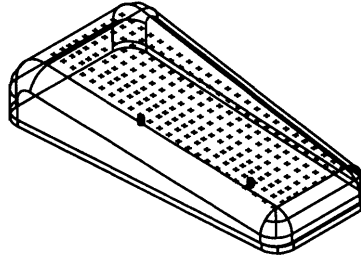

AD [6PCS]



AE [2PCS]



AF [1PCS]

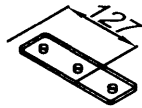

AG [1PCS]

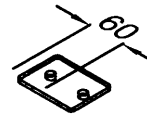

AH [1PCS]

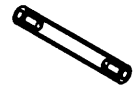

## ASSEMBLY-STEP 1

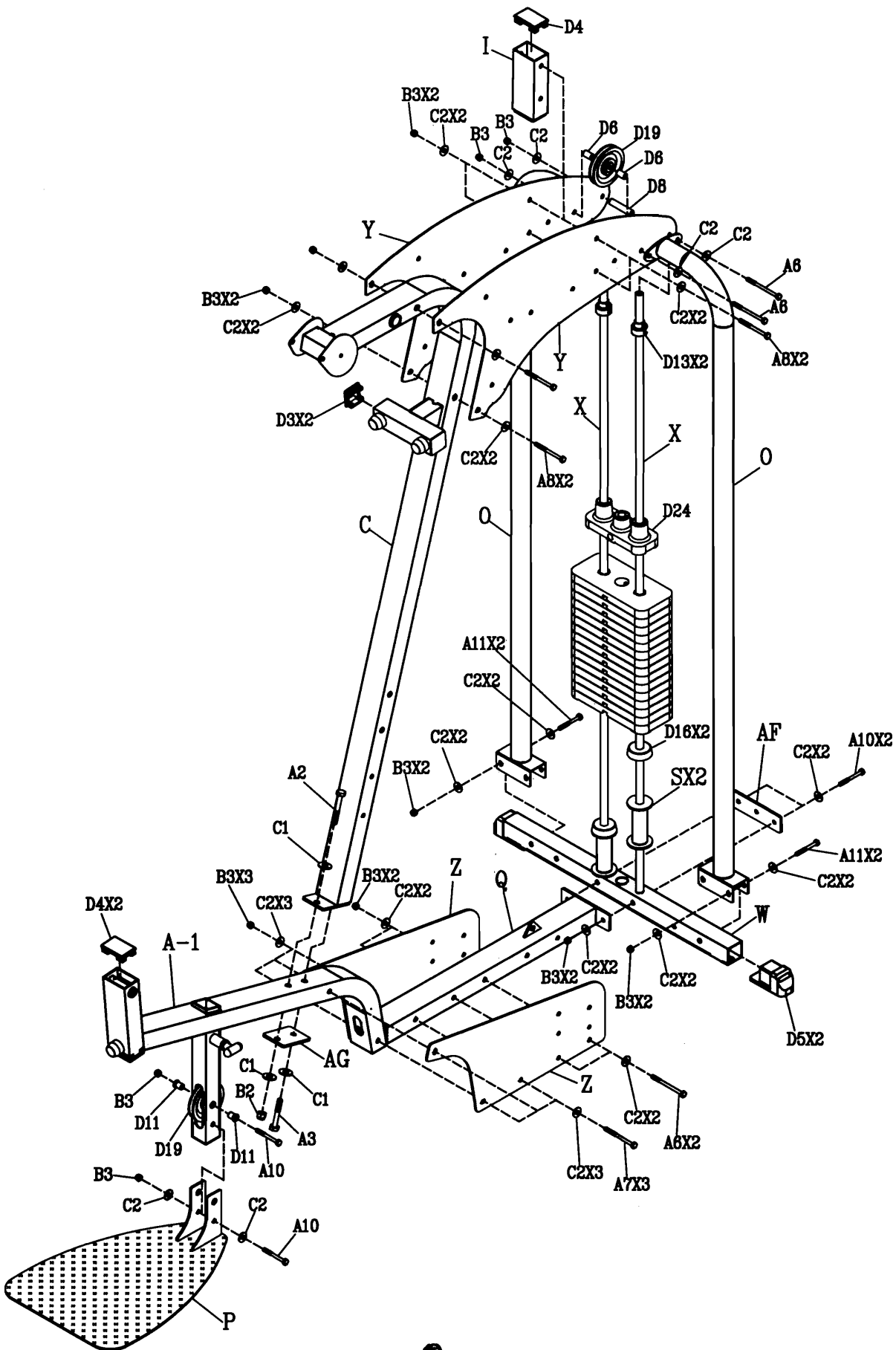

## ASSEMBLY-STEP 2

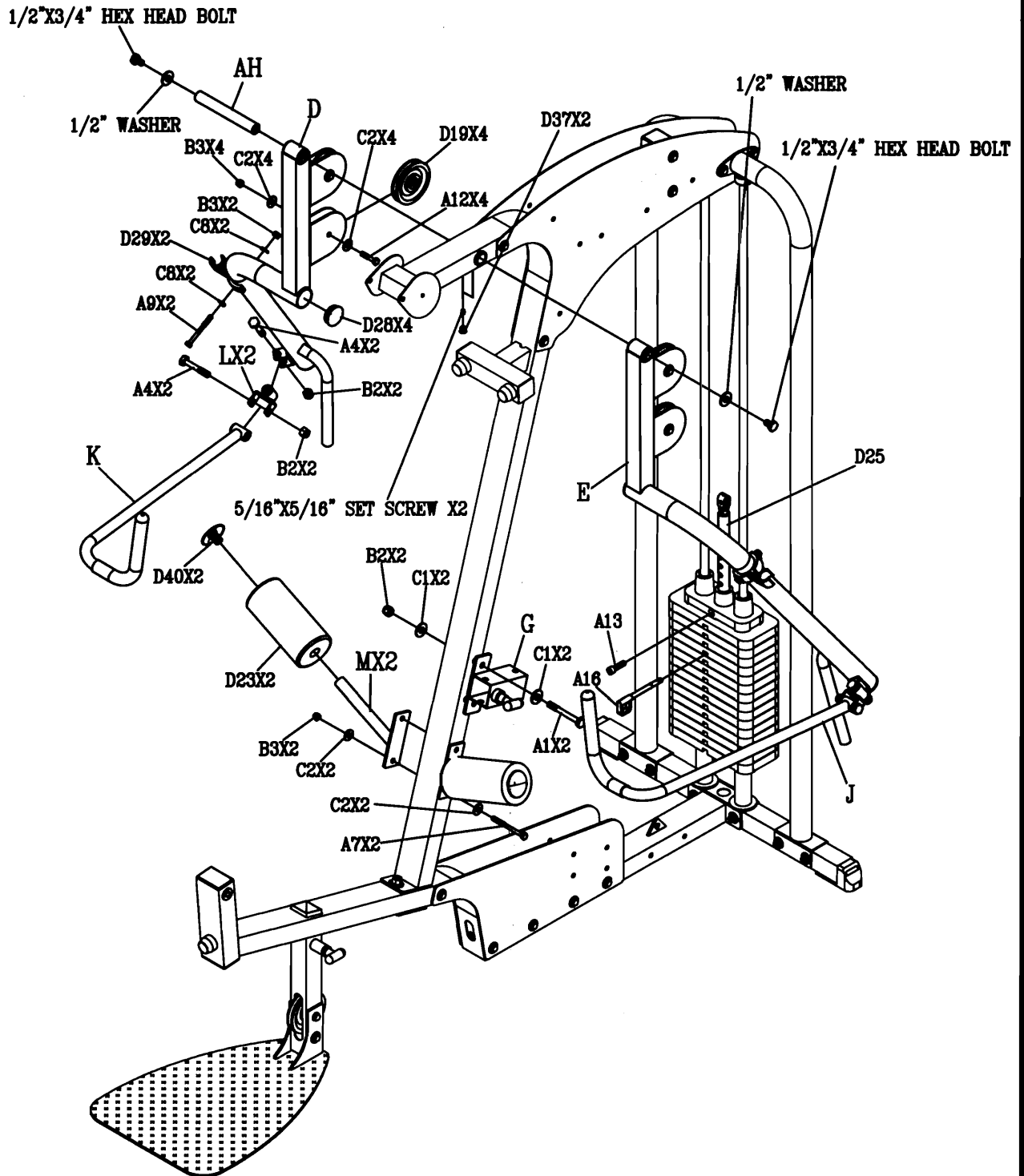



## ASSEMBLY-STEP 3

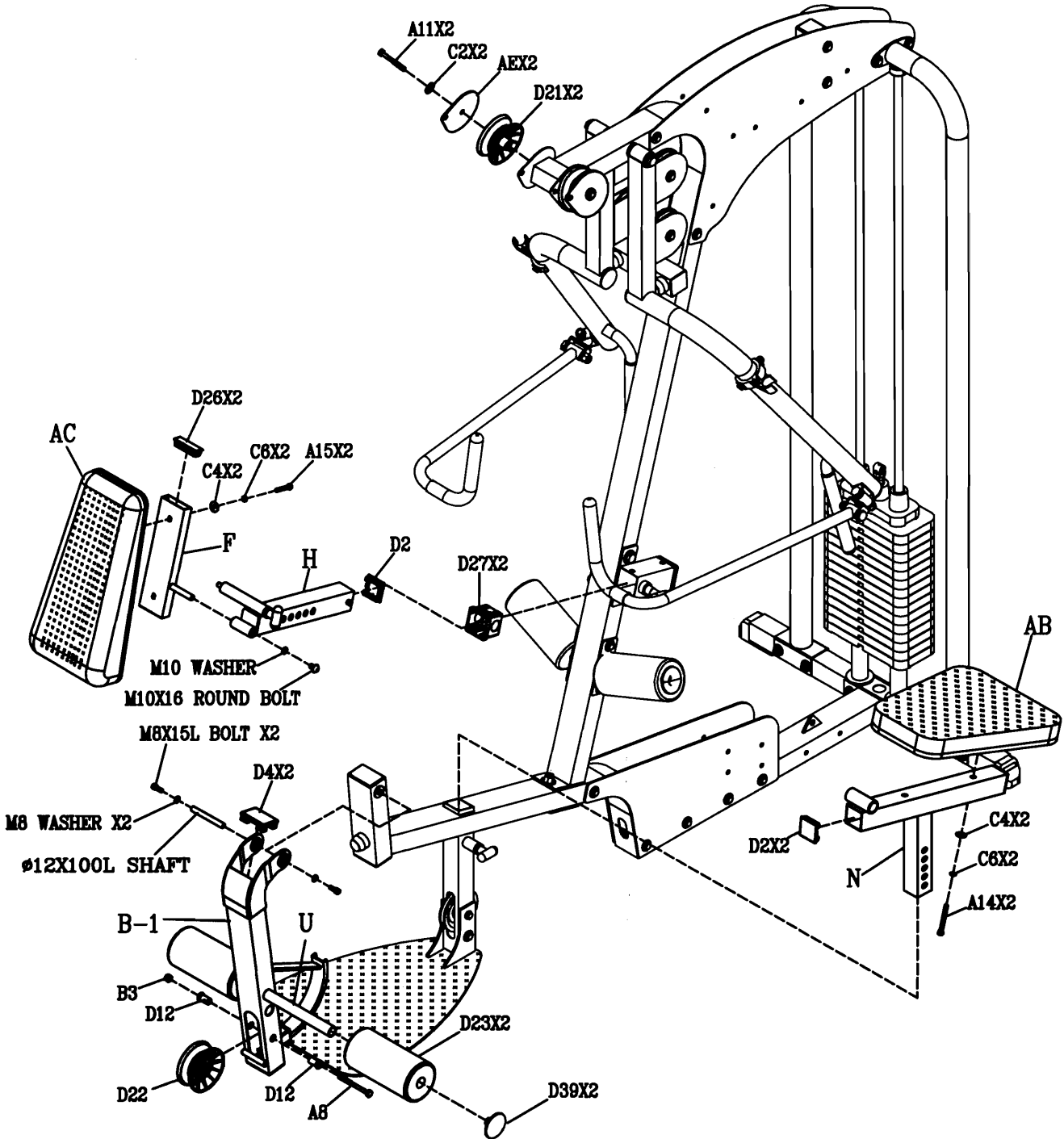

## ASSEMBLY-STEP 4

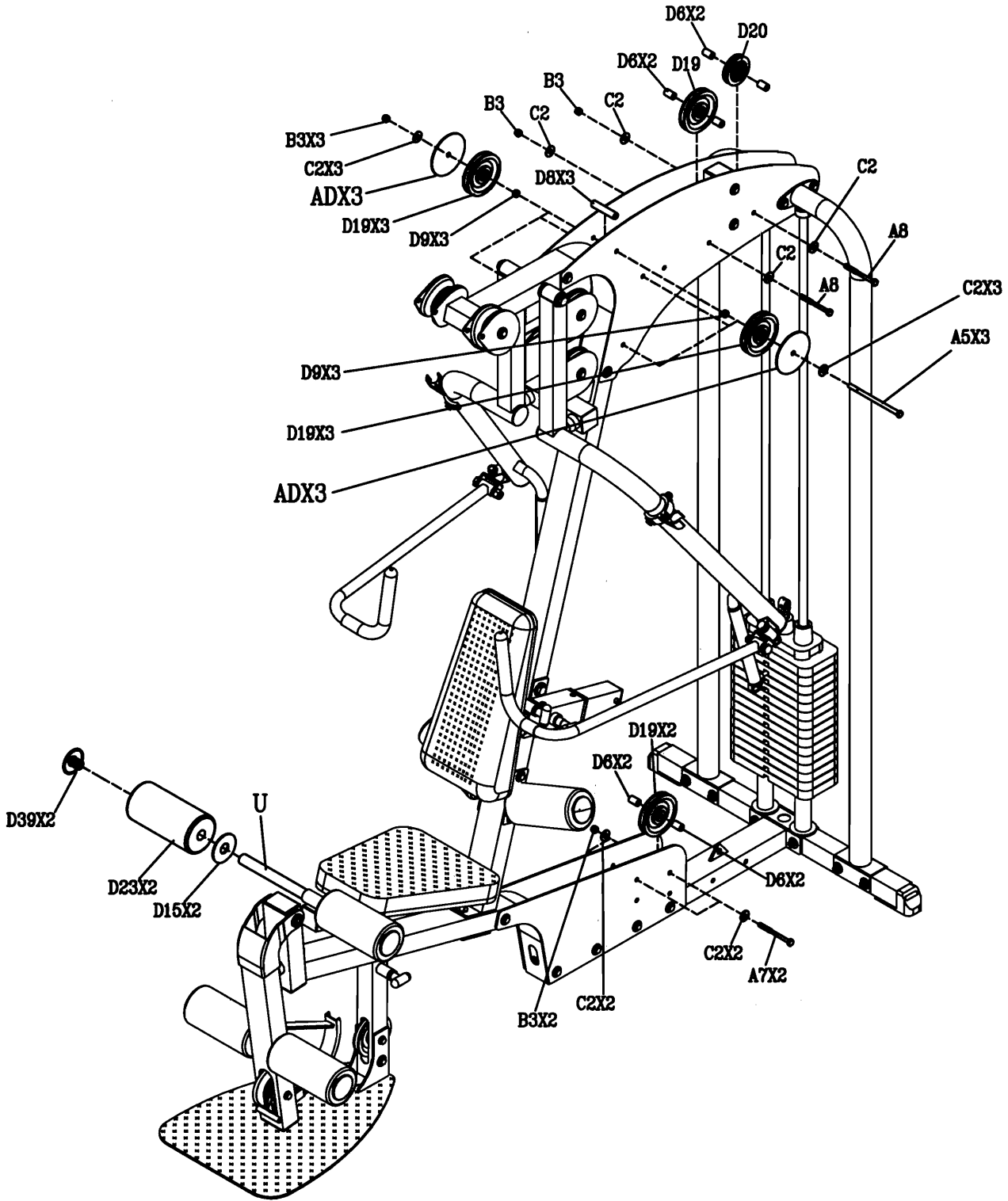

# EXM1950 ASSEMBLY INSTRUCTIONS

## ASSEMBLY-STEP 5

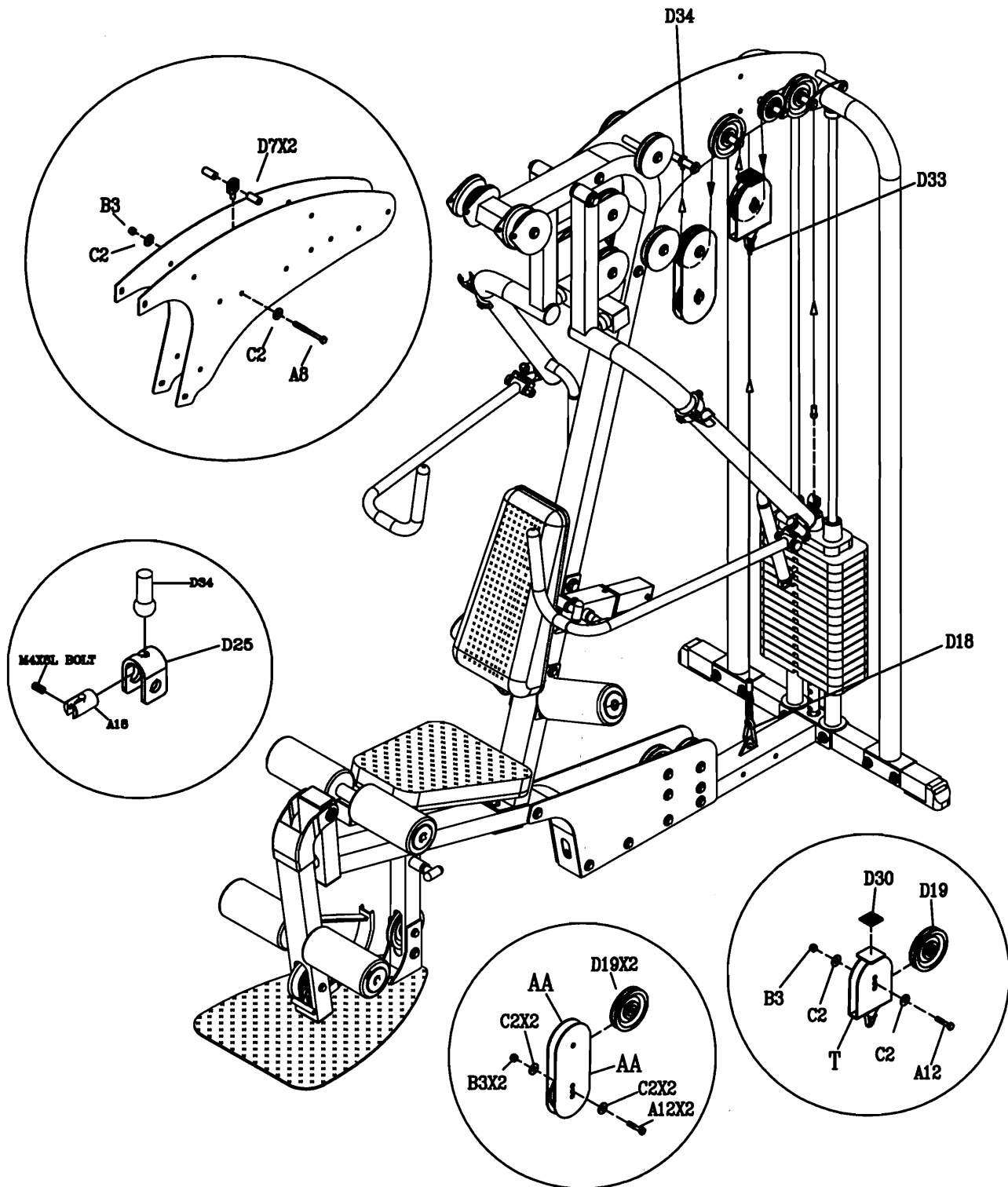

## ASSEMBLY-STEP 6

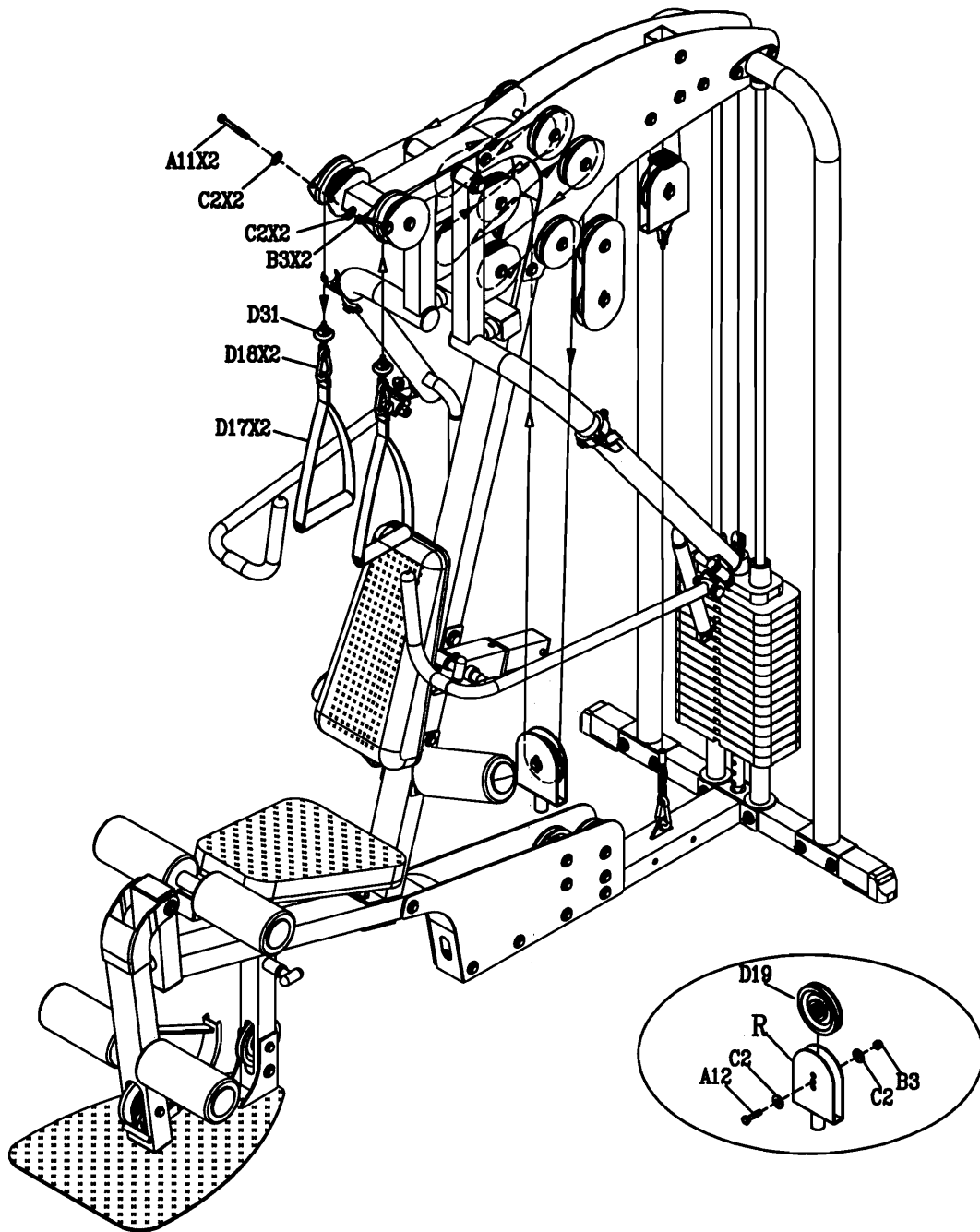

## ASSEMBLY-STEP 7

THERE IS A RISK ASSUMED BY INDIVIDUALS WHO USE THIS TYPE OF EQUIPMENT. TO MINIMIZE RISK, YOU MUST FOLLOW THESE RULES:

1. Inspect equipment before each workout. Check that all nuts, bolts, screws and pop pins are in place and fully tightened. Also, before use, check cables for signs of wear. Replace all worn parts immediately. Never use machine if any parts are damaged or missing. Failure to follow these rules may result in serious injury.
2. Keep clear of the cables and all moving parts when the machine is in use.
3. Always make sure all Snap Links are closed when doing any cable/pulley exercises.
4. Exercise with care. Perform your exercises at a smooth moderate pace; never perform jerky or uncoordinated movements that may cause injury.
5. It is recommended that you should workout with a training partner.
6. Do not allow children or minors to play on or around this equipment.
7. If unsure of proper use of equipment, call your local Body-Solid distributor or the Body-Solid customer service department at 1-800-556-3113.
8. **WARNING:** Consult your physician before starting your exercise program. For your own safety, do not begin any exercise program without proper instruction.

RA12-11-98

